

4

3

2

1

D

D

C

C

B

B

A

A

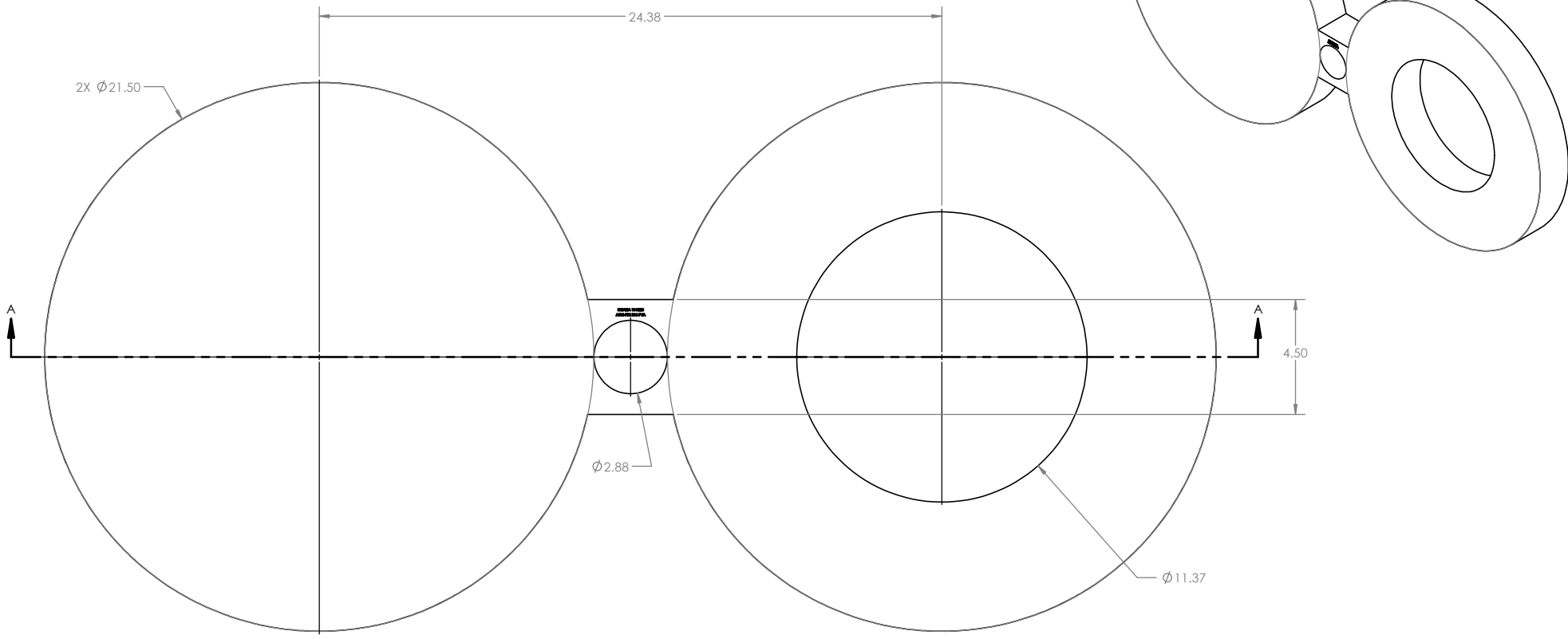

2X  $\phi$ 21.50

24.38

4.50

$\phi$ 2.88

$\phi$ 11.37

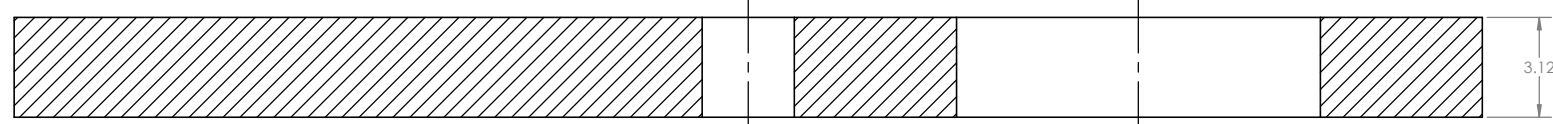

3.12

SECTION A-A

DO NOT SCALE PRINT		UNLESS OTHERWISE SPECIFIED: OUTSIDE DIAMETER: (+/-0.12) INSIDE DIAMETER: (+/-0.12) THICKNESS TOLERANCES (-ZERO +0.12) ALL UNITS IN INCHES OR POUNDS		<b>HYDROBLIND -ISOLUTIONS</b>
MATERIAL: CUSTOMER REQUESTED		SHEET 1 OF 1		
DATE: 07/07/2020		DIMENSIONS & TOLERANCES TO BE IN ACCORDANCE WITH ASME B16.48		DRAWING TITLE: 12CL 2500 FIGURE 8 BLIND
SCALE 1:3	SIZE <b>C</b>	DRAWING NUMBER: GSBT		WEIGHT 552 lb REV 00

4

3

2

1